

High-Pressure Pulse Radiolysis as a Tool in the Study of Transition Metal Reaction Mechanisms

RUDI VAN ELDIK[†] AND DAN MEYERSTEIN^{*‡}

Institute for Inorganic Chemistry, University of Erlangen-Nuernberg, Egerlandstrasse 1, 91058 Erlangen, Germany, Chemistry Department, Ben-Gurion University of the Negev, Beer-Sheva, Israel, and The College of Judea and Samaria, Ariel, Israel

Received April 21, 1999

ABSTRACT

The unique combination of high-pressure and pulse radiolysis kinetic techniques enables detailed mechanistic insight for a large variety of chemical processes to be gained. Typical examples for transition metal reactions are presented. These include ligand substitution, electron transfer, reactions of complexes with uncommon oxidation states, and reactions with radicals, including the formation and decomposition reactions of complexes with metal-carbon σ bonds. The volumes of activation and volume profiles obtained form the basis of a critical analysis of different plausible reaction mechanisms.

Pulse radiolysis is a powerful technique for the elucidation of a variety of inorganic reaction mechanisms, especially in aqueous solutions.¹ This technique is based on the formation of the radicals e^-_{aq} , H^\cdot , and $\cdot OH$ by the radiolysis of water.¹ These radicals can be transformed into a single reducing or oxidizing radical, or a mixture thereof, via the use of suitable scavengers.¹ In pulse radiolysis experiments, observable concentrations of the desired radical are formed within a short period, e.g., $<2 \mu s$. Therefore, this technique is the optimal one for the study of the kinetics and mechanisms of the reactions of a large variety

Rudi van Eldik was born in Amsterdam, Holland, in 1945 and grew up in Johannesburg, South Africa. He received his Ph.D. degree (1971) from the Potchefstroom University. He spent two years (1972 and 1978) with Gordon M. Harris at SUNY at Buffalo, NY, and one year as an Alexander von Humboldt Fellow with Hartwig Kelm at the University of Frankfurt, Germany. He was group leader at the Institute for Physical Chemistry, University of Frankfurt (1980–1987) and Professor of Inorganic Chemistry at the University of Witten/Herdecke (1987–1994). He is presently Professor of Inorganic and Analytical Chemistry at the University of Erlangen-Nurnberg. In 1997 he received an honorary doctorate from the Potchefstroom University. His research interests are in mechanistic studies of inorganic, organometallic, and bioinorganic reactions, with special emphasis on the application of fast kinetic and high-pressure techniques.

Dan Meyerstein was born in Jerusalem, Israel, in 1938. He received his M.Sc. (1961) and Ph.D. (1965) degrees from the Hebrew University of Jerusalem. He spent three years (1966–67 and 1978) with Dr. Max S. Matheson at Argonne National Laboratory, Argonne, IL. Since 1968 he has been at the Ben-Gurion University of the Negev, Beer-Sheva, Israel, where he has been the Irene Evens Professor of Inorganic Chemistry since 1987. He was president of the Israel Chemical Society (1988–1991). Since 1995 he has been president of the College of Judea and Samaria, Ariel, Israel. He received the Meitner-Humboldt Research Prize (1997) and the Koltzoff Prize (1998). His main research interests include radical reactions with transition metal complexes, transition metal complexes with uncommon oxidation states, ligand design, complexes with metal-carbon σ bonds in aqueous solution, catalysis using pulse radiolysis, stopped-flow, electrochemistry, etc.

of radicals with different substrates and the study of the properties of transients formed in these reactions, as well as for the study of the chemical properties of transition metal complexes with uncommon oxidation states, e.g., Ni(I),^{2,3} Co(I),⁴ Zn(I),² Ni(III),⁵ Cu(III),⁶ and Fe(V).⁷

Thus, pulse radiolysis enables the study of the properties of key intermediates in a large variety of catalytic processes. This technique is also used for the study of fast reactions between relatively stable compounds, e.g., reactions of Ni^{III}edta⁻,⁸ Cu(phen)₂⁺,⁹ Cr(H₂O)₆²⁺,¹⁰ and nickel (1,4,8,11-tetramethyl-1,4,8,11-tetraazacyclotetradecane)⁺¹¹ with dioxygen; ligand exchange reactions on Cu(I),¹² Co(II),¹³ and Ru(II),¹³ and redox processes, e.g., the reactions of Cu⁺_{aq} with Cl₃CCOO⁻¹⁴ and ONOO⁻ with I⁻.¹⁵

The measurement of the volume of activation, ΔV^\ddagger , and the overall reaction volume, ΔV° , has been shown to be a powerful technique to obtain detailed information on the nature of the transition state for a large variety of inorganic reactions.¹⁶ The volume of activation is determined from rate constant (k) measurements performed as a function of pressure (usually in the range 0.1–200 MPa) and from application of the relationship $(\sigma \ln k/\sigma P)_T = -\Delta V^\ddagger/RT$. Special instrumentation is required to perform kinetic experiments at elevated pressure. ΔV^\ddagger can be determined rather accurately from the slope of $\ln k$ vs P . The overall reaction volume can be determined from the difference in the partial molar volumes of the reactant and product species (usually obtained from density measurements), or from the pressure dependence of the equilibrium constant (similar to that given for a rate constant above) in the case of a reversible reaction. From this information, a volume profile for a particular reaction can be constructed, which represents the chemical process in terms of volume changes along the reaction coordinate.¹⁶ Such volume changes can be analyzed in terms of intrinsic (due to changes in bond lengths and bond angles) and solvational (due to changes in electrostriction as a result of changes in charge and/or dipole moment) volume contributions. There are numerous examples now available from the literature of cases in which this technique has contributed significantly to the elucidation of the intimate mechanisms of thermal and photoinduced reactions in inorganic, bioinorganic, and organometallic chemistry.¹⁶

It seemed therefore logical to combine these unique techniques and to measure ΔV^\ddagger and ΔV° for reactions studied by pulse radiolysis with the aim of obtaining a more detailed insight into the mechanisms of such processes. The main difficulty in developing the combined technique was that, in many pulse radiolysis setups, electrons with an energy ≤ 5 MeV are used. The penetration of these electrons through windows which are resistant to high pressure, e.g. sapphire, is limited. A stainless steel window with a special geometric design (Figures 1 and 2) was therefore required. This window

[†] University of Erlangen-Nuernberg.

[‡] Ben-Gurion University of the Negev and The College of Judea and Samaria.

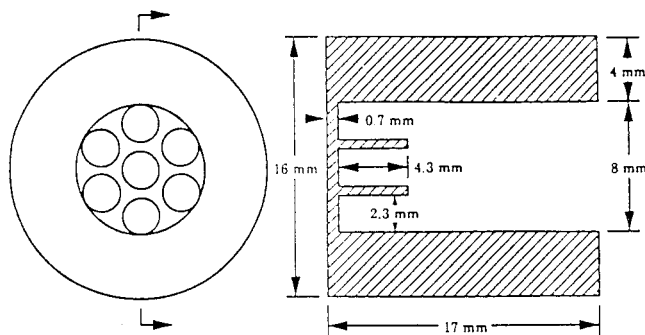

FIGURE 1. Schematic diagram of the electron beam window for high-pressure pulse radiolysis. The electron beam enters from the right side.

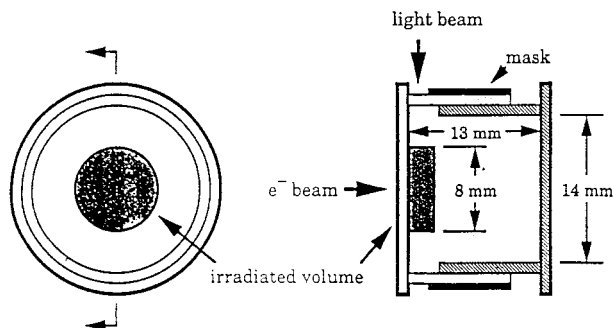

FIGURE 2. Schematic diagram of the pillbox sample cell showing the electron beam and light beam paths and the irradiated volume.

enables the study of a large variety of processes using the pulse radiolysis technique at pressures up to 200 MPa.¹⁷

It should be kept in mind that measurement of volumes of activation is meaningful only for processes which meet the following criteria:¹⁶

(1) The process is not diffusion controlled, or approaching this limit, since such studies measure the effect of pressure on the diffusion rate.

(2) The process is not pH dependent in the pH range $5 \leq \text{pH} \leq 9$, as the dissociation of water depends on pH and is affected by pressure.

(3) The process is not general base or acid catalyzed, as the dissociation of any acid or base strongly depends on the pressure. Therefore, for a system of the type

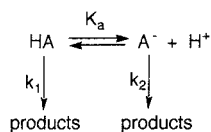

measurements if $k_1 \gg k_2$ are meaningful only at $\text{pH} < \text{p}K_a - 1$, and if $k_2 \gg k_1$ only at $\text{pH} > \text{p}K_a + 1$.

(4) The process is not complex, i.e.,

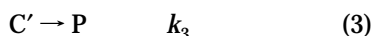
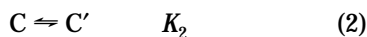

where the equilibria 1 and 2 are fast, $K_1 \ll 1$, $K_2 \ll 1$, and k_3 is the rate-determining step. In such systems, the

measured ΔV^\ddagger equals $\Delta V_1^\circ + \Delta V_2^\circ + \Delta V_3^\ddagger$ and usually cannot be separated for each step in the process.

In the following sections the application of high-pressure pulse radiolysis in different types of reactions is discussed.

Oxidations by $\cdot\text{OH}$ Radicals

Most of the reactions of $\cdot\text{OH}$ radicals with low-valent transition metal complexes have specific rates approaching the diffusion-controlled limit. There is no point in studying their pressure dependence, since pressure will only affect the viscosity of the medium, which in turn will control the diffusion process. One of the exceptions is the oxidation of $[\text{Cu}(\text{H}_2\text{O})_n]^{2+}$ and $[\text{Cu}(\text{P}_2\text{O}_7)_2(\text{H}_2\text{O})_2]^{6-}$ by hydroxyl radicals. The volumes of activation for these reactions are close to zero, i.e., $+0.7^{18}$ and $-1.8 \text{ cm}^3 \text{ mol}^{-1}$,¹⁹ respectively. These results rule out the possibility that electron transfer via either the outer-sphere or the inner-sphere mechanisms is the rate-determining step:¹⁸ Electron-transfer steps which involve the creation of

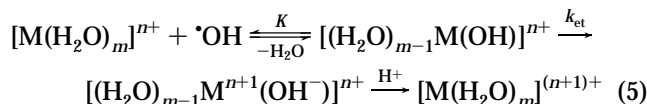
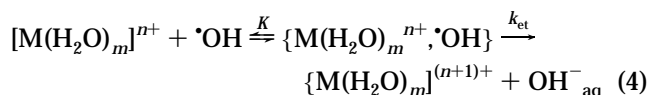

charges are expected to have significant negative volumes of activation due to changes in electrostriction.¹⁶ Also, hydrogen abstraction from one of the water molecule ligands according to

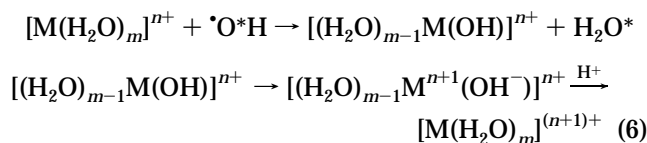

(where the asterisk is introduced to distinguish this reaction from reaction 7 below) can be ruled out, as the hydrogen abstraction can occur only if the OH in the product strongly interacts with the central cation, i.e., if partial oxidation, and therefore an increase in electrostriction, occurs in the abstraction step.¹⁸ It was therefore concluded¹⁸ that the almost zero volume of activation favors the following mechanism:

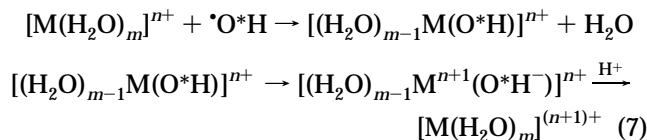

where the rate-determining step involves ligand exchange. This ligand exchange reaction then has to proceed via an interchange mechanism, I, and in the case of $[\text{Cu}(\text{P}_2\text{O}_7)_2(\text{H}_2\text{O})_2]^{6-}$ probably via a slightly associative interchange mechanism, I_a ,¹⁹ in order to rationalize the small volumes of activation observed.

Oxidation by Other Inorganic Radicals

The volumes of activation for the oxidation of a variety of Mn(II), Fe(II), Co(II), and Ni(II) complexes by $\text{Br}_2^{\cdot-}$, $(\text{SCN})_2^{\cdot-}$, $\cdot\text{O}_2\text{CH}_3$, and HO_2^{\cdot} were measured.^{20,21} The results clearly indicate that the rate-determining step in all these reactions, which proceed via the inner-sphere mechanism, forming $\text{M}^{\text{III}}\text{X}$ (where $\text{X} = \text{Br}, \text{SCN}, \text{O}_2\text{CH}_3, \text{ or } \text{O}_2\text{H}$), is the ligand interchange step. The volumes of activation are small, slightly positive ($< 6 \text{ cm}^3 \text{ mol}^{-1}$) for the Ni(II) and Co(II) complexes, i.e., indicating an I_d mechanism, and around zero or slightly negative (-1 to $-4 \text{ cm}^3 \text{ mol}^{-1}$) for the Fe(II) and Mn(II) complexes, i.e., indicating a pure I or an I_a mechanism for these complexes, in agreement with expectations.²⁰ The displacement of coordinated water by a nucleophile in these reactions closely resembles the water exchange process on such metal complexes, for which typical volumes of activation of around $+6$ and $-6 \text{ cm}^3 \text{ mol}^{-1}$ for I_d and I_a mechanisms, respectively, have been reported.¹⁶ In the case of limiting D and A mechanisms, significantly larger values of around $+13$ and $-13 \text{ cm}^3 \text{ mol}^{-1}$, respectively, are expected.

For the oxidation of a series of Fe(II) complexes by $\text{Br}_2^{\cdot-}$ an interesting trend is observed.²⁰ The faster the reaction, i.e., the faster the ligand exchange process, the more negative the volume of activation. In other words, the more labile complexes tend to react via an I_a mechanism, whereas the less labile complexes react via an I_d or a pure I mechanism.²⁰ Alternatively, it could be argued that the faster reactions involve an "early" transition state, i.e., mainly an associative process, and the slower reactions involve a later transition state, i.e., at a stage where partial Br–Br bond breakage already occurs.

For the oxidation of $[\text{Mn}^{\text{II}}(\text{N}(\text{CH}_2\text{CH}_2\text{CO}_2^-)_3)_{\text{aq}}]$ by $(\text{SCN})_2^{\cdot-}$, $\Delta V^\ddagger = 2.8 \text{ cm}^3 \text{ mol}^{-1}$; i.e., surprisingly a small positive volume of activation is observed.²⁰ This observation is probably related to the fact that this reaction is considerably less exothermic than the others studied and therefore has a relatively late transition state.

Of special interest is the oxidation of $[\text{Ni}^{\text{II}}(\text{trans-III-C-meso-5,7,7,12,14,14-hexamethyl-1,4,8,11-tetraazacyclotetradecane})]^{2+}$, $\text{Ni}^{\text{II}}\text{L}$, by HO_2^{\cdot} .²¹ This reaction is endothermic in the absence of a stabilizing axial ligand, e.g., SO_4^{2-} . The reaction occurs, therefore, only in the presence of such a ligand. The experimental data are in accord with the mechanism presented in Scheme 1. A detailed study enabled the determination of the following values: $\Delta V^\ddagger(k_3) = 1.4 \pm 1.0 \text{ cm}^3 \text{ mol}^{-1}$; $\Delta V^\ddagger(k_2) = -7.2 \pm 1.0$ and $-7.7 \pm 1.0 \text{ cm}^3 \text{ mol}^{-1}$ for $\text{X} = \text{SO}_4^{2-}$ and H_2PO_4^- , respectively;²¹ $\Delta V^\circ(K) = 7 \pm 2$ and $-5 \pm 2 \text{ cm}^3 \text{ mol}^{-1}$ for $\text{X} = \text{SO}_4^{2-}$ and H_2PO_4^- , respectively.²¹ The values of $\Delta V^\circ(K)$ are in accord with expectations for the electrostatic interaction of a $2+$ cation with $2-$ and $1-$ charged nucleophiles.²¹ The value of $\Delta V^\ddagger(k_3)$ is in accord with the suggestion that the rate-determining step of this reaction is a ligand exchange process occurring via the I_d mechanism.²¹ This is a surprising result as the $\text{Ni}^{\text{II}}\text{L}$ complex has a low-spin d^8 planar configuration. It was therefore concluded that water molecules must be present at some distance along

Scheme 1. Mechanism of Oxidation of $\text{Ni}^{\text{II}}\text{L}$ by HO_2^{\cdot}

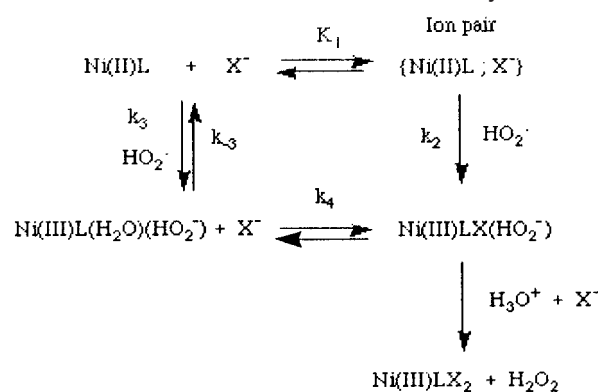

the Z axis and have to be displaced in the process. This conclusion is in accord with earlier observations.²² The formation of the contact ion pairs, $\{\text{Ni}^{\text{II}}\text{L}; \text{X}^-\}$, accelerates the rate of the reaction; i.e., k_2 is ca. 10 times larger than k_3 , and under these conditions the reaction with the HO_2^{\cdot} radicals becomes an associative process, as expected for a low-spin planar d^8 nickel complex.²¹

Reactions of Transition Metal Complexes with Alkyl Radicals: Formation of Metal–Carbon σ Bonds

In principle, the reactions

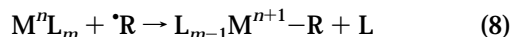

are inner-sphere oxidation processes. Indeed, the measurement of the volumes of activation for the reactions of $\cdot\text{CH}_3$ radicals with $[\text{Cr}(\text{H}_2\text{O})_6]^{2+}$ ($+6.3 \text{ cm}^3 \text{ mol}^{-1}$),²³ $[\text{Fe}^{\text{II}}(\text{nta})(\text{H}_2\text{O})_2]^-$ ($-0.3 \text{ cm}^3 \text{ mol}^{-1}$),²⁰ $[\text{Co}^{\text{II}}(\text{nta})(\text{H}_2\text{O})_2]^-$ ($+6.0 \text{ cm}^3 \text{ mol}^{-1}$),²⁴ and $[\text{Ni}^{\text{II}}(\text{trans-III-1,4,8,11-tetraazacyclotetradecane})]^{2+}$ (NiL^{2+}) ($+4.0 \text{ cm}^3 \text{ mol}^{-1}$)²² points out that the rate-determining step of all these reactions is the ligand interchange step, pure I for the $[\text{Fe}^{\text{II}}(\text{nta})(\text{H}_2\text{O})_2]^-$ system and I_d for the other systems.²⁰

Of special interest is the study of the reaction of $[\text{Cr}(\text{H}_2\text{O})_6]^{2+}$ with a variety of alkyl radicals.²³ The specific rates of these reactions for a large variety of radicals, with a varying degree of steric hindrance, are in the range $2 \times 10^7 \leq k \leq 3 \times 10^8 \text{ M}^{-1} \text{ s}^{-1}$. Furthermore, the volumes of activation of these reactions are all small positive, with an average value of $4.3 \pm 1.0 \text{ cm}^3 \text{ mol}^{-1}$.²³ These results indicate that the rate-determining step in these reactions is the ligand exchange step and that this step occurs via the I_d mechanism. This observation suggests that ligand and solvent exchange on $\text{Cr}(\text{H}_2\text{O})_6^{2+}$ occurs via the I_d mechanism, and not via the I_a mechanism which occurs for the analogous reactions on $\text{V}(\text{H}_2\text{O})_6^{2+}$ and $\text{Mn}(\text{H}_2\text{O})_6^{2+}$. The deviation for $\text{Cr}(\text{H}_2\text{O})_6^{2+}$ is attributed to the Jahn–Teller distortion, which facilitates a dissociative mechanism.²³ As the volume of activation of the homolysis reaction

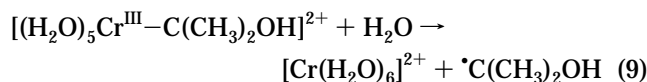

Scheme 2. Volume Profile for the Formation and Homolysis of $[(\text{H}_2\text{O})_5\text{Cr}^{\text{III}}-\text{C}(\text{CH}_3)_2\text{OH}]^{2+}$ ($\text{R} = \cdot\text{C}(\text{CH}_3)_2\text{OH}$; Volumes in Units of $\text{cm}^3 \text{mol}^{-1}$)

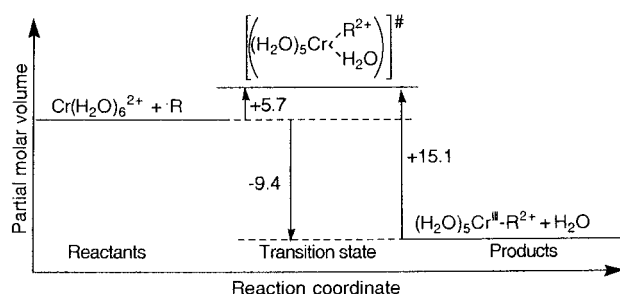

was known,²⁵ the full volume profile for this equilibrium process could be constructed (Scheme 2). This scheme clearly demonstrates that the formation and homolysis of the Cr–C bond have a dissociative character, as expected. The partial molar volume of the transition state of this reaction is significantly larger than those of the reactant and the product species.

A special case is the effect of acetate on the reaction of $\cdot\text{C}(\text{CH}_3)_2\text{OH}$ radicals with Cr(II).²⁶ The addition of acetate slows the rate of the reaction. An analysis of the data suggests that the complexes $[\text{Cr}(\text{H}_2\text{O})_6]^{2+}$, $[\text{Cr}(\text{H}_2\text{O})_5(\text{CH}_3\text{CO}_2^-)]^+$, and $[\text{Cr}(\text{H}_2\text{O})_4(\text{CH}_3\text{CO}_2^-)_2]$ have a similar reactivity toward the radical, whereas the dimer, $[\text{Cr}(\text{H}_2\text{O})(\text{CH}_3\text{CO}_2^-)_2]_2$, is practically unreactive.²⁶ This observation clearly demonstrates that the quadruple Cr–Cr bond considerably affects the rate of the ligand exchange of the axial water ligand. Also, the volume of activation for the reaction decreases and becomes more negative on increasing the acetate concentration. This effect is attributed to the large negative reaction volume for the dissociation of the dimer, and not to an intrinsic property of the reaction with the radical.²⁶

Homolysis of Metal–Carbon σ Bonds

The volume of activation for the homolysis of the metal–carbon σ bond in $[(\text{nta})(\text{H}_2\text{O})\text{Co}^{\text{III}}-\text{CH}_3]^-$ ²⁴ and in $[\text{L}'(\text{H}_2\text{O})\text{Ni}^{\text{III}}-\text{CH}_3]^{2+}$ ²² was determined by following the homolytic insertion of dioxygen into the metal–carbon σ bond, which occurs via the reactions

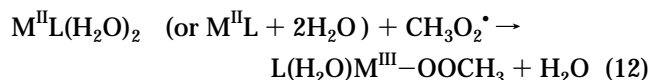
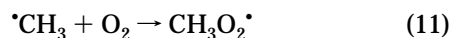
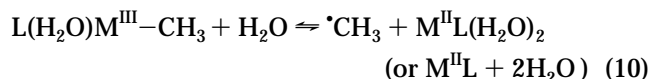

The results are summarized in Schemes 3 and 4. A comparison of the results presented in Schemes 2–4 reveals several interesting conclusions:^{22,24}

(1) All the reactions proceed via an I_d mechanism. This means that measuring ΔH^\ddagger of the homolysis reaction does not yield the M–C bond strength as proposed in the literature.²⁴

Scheme 3. Volume Profile for the Reverse Reaction 10, $\text{M}^{\text{II}}\text{L}(\text{H}_2\text{O})_2 = \text{Co}^{\text{II}}(\text{nta})(\text{H}_2\text{O})_2^-$ (Volumes in Units of $\text{cm}^3 \text{mol}^{-1}$)

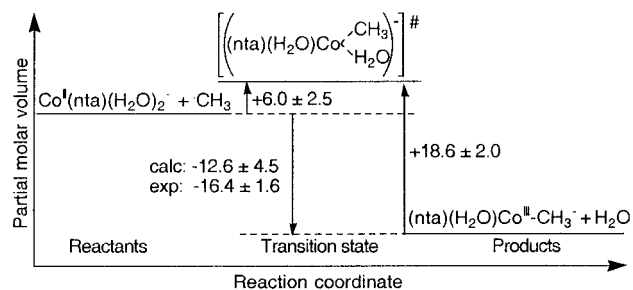

(2) The volume of reaction 8 is always significantly negative, as expected for an associative process which furthermore involves partial oxidation of the central cation. However, the absolute values of the reaction volumes, ΔV° , are more complex to interpret: (a) The value observed in the chromium system²³ (Scheme 2) is in accord with expectations based on the known partial molar volumes of the exchanging radical and water ligand. (b) The considerably more negative ΔV° in the cobalt system²⁴ (Scheme 3) is somewhat surprising and is attributed to the large difference in the radii of high-spin Co^{II} and low-spin Co^{III} complexes. (c) The even larger negative ΔV° observed in the nickel system²² (Scheme 4) is attributed to the fact that the $\text{Ni}^{\text{II}}\text{L}'$ complex is a low-spin d^8 planar complex. Thus, the two water molecules located near the nickel divalent cation in Scheme 4 are not bound to it but are rather located in cavities formed by the macrocyclic ligand.²² The oxidation of the complex forms an octahedral low-spin d^7 complex. Thus, a water molecule is ligated as an additional ligand during the oxidation reaction. This change in the coordination sphere accounts for the large negative ΔV° observed. Finally, in theoretical simulations of complexes with $\text{Ni}^{\text{III}}-\text{C}$ bonds,²⁷ octahedral and not pentacoordinated complexes, as recently suggested, have to be considered.

Heterolysis of Metal–Carbon σ Bonds

Heterolysis of the metal–carbon bond,

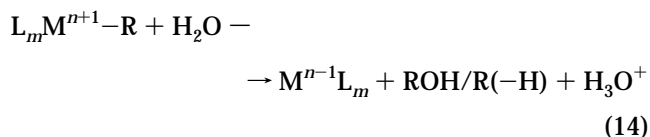
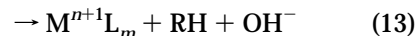

is the major decomposition mechanism of complexes with metal–carbon σ bonds in aqueous solutions. The activation volumes for the heterolysis of several, relatively stable complexes, e.g., $[(\text{H}_2\text{O})_5\text{Cr}^{\text{III}}-\text{CH}_2\text{OH}]^{2+}$, with a $\text{Cr}^{\text{III}}-\text{C}$ bond which proceed via reaction 13 were measured.²⁵ These reactions are acid catalyzed; i.e., their rate of reaction obeys the equation $k_{13} = k^\circ + k^{\text{H}}[\text{H}_3\text{O}^+]$. It was found that ΔV^\ddagger for both the acid-independent and acid-catalyzed pathways are approximately zero.²⁵ This result was interpreted as suggesting that reaction 13 can be

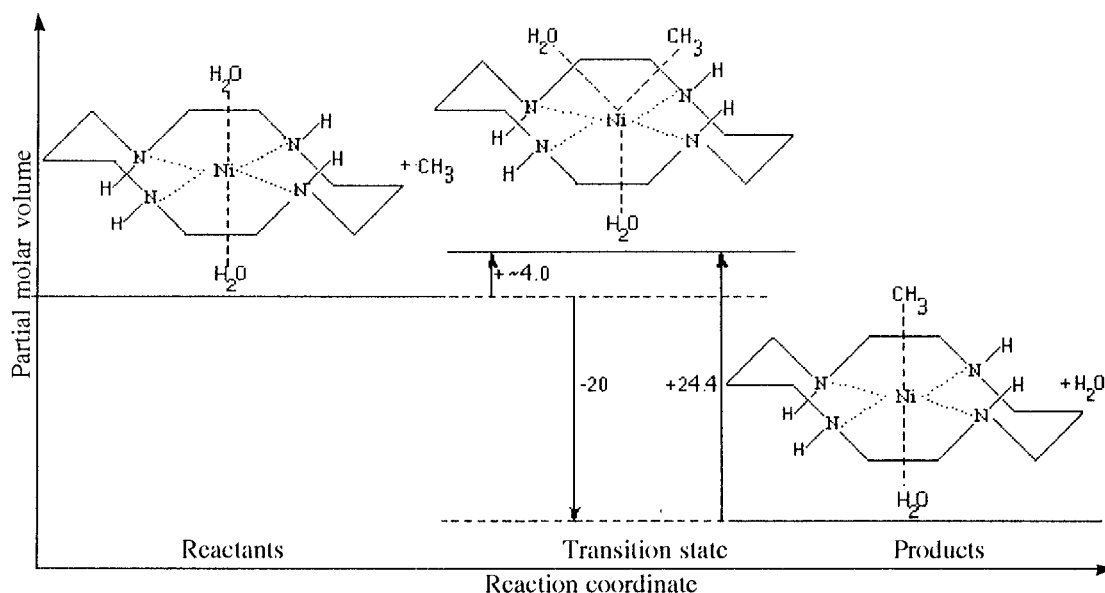
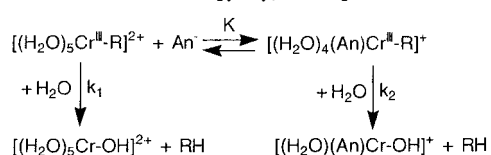
Scheme 4. Volume Profile for the Reverse Reaction 10, $M^{\text{II}}L(H_2O)_2 = Ni(L')(H_2O)_2^{2+}$ (Volumes in Units of $\text{cm}^3 \text{mol}^{-1}$)Scheme 5. General Base Catalysis of the Heterolysis of $\text{Cr}^{\text{III}}-\text{C}$ Bonds in $[(H_2O)_5\text{Cr}^{\text{III}}-\text{R}]^{2+}$ 

considered as a substitution reaction of the $\text{Cr}(\text{III})$ central cation which occurs via an interchange, I , mechanism.²⁵

Reaction 13 for $M^{n+1} = \text{Cr}^{\text{III}}$ was shown to be also general base catalyzed; i.e., it proceeds via the mechanism described in Scheme 5.²⁸ The volumes of activation for several of these reactions were measured.²⁸ It was found that for a large variety of anions, An^- , $\Delta V^\ddagger(k_2) \approx 10 \text{ cm}^3 \text{mol}^{-1}$. These results were interpreted as indicating that the An^- ligand, usually in the trans position to R , weakens the $\text{Cr}^{\text{III}}-\text{C}$ bond, thus shifting the mechanism from a pure I to an I_d mechanism.²⁸

To check whether the positive volume of activation is, indeed, due to an intrinsic effect induced by the An^- ligand, and not just due to the higher rate of reaction, ΔV^\ddagger for the heterolytic decomposition of $[(H_2O)_5\text{Cr}^{\text{III}}-\text{CH}_2\text{CH}(\text{OH})_2]^{2+}$ was measured.²⁹ The rate of heterolysis of the $\text{Cr}^{\text{III}}-\text{C}$ bond in this complex is considerably faster than that of k_2 for the anion-catalyzed reactions. However, ΔV^\ddagger is only 3.3 and 1.9 $\text{cm}^3 \text{mol}^{-1}$ for the spontaneous and acid-catalyzed pathways of this reaction.²⁹ This result, therefore, confirms the earlier conclusions.

$\Delta V^\ddagger = -8.7 \text{ cm}^3 \text{mol}^{-1}$ was determined²⁹ for the reaction

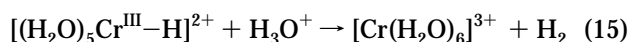

which is the fastest of these reactions. This result is in agreement with the small size of the leaving group, which is overruled by the volume decrease due to the coordination of the larger water molecule and the net concentration of charge.

Decomposition of Complexes with Metal—Carbon σ Bonds via β -Elimination Reactions

Many complexes of the type $L_m M^{n+1}-\text{CR}^1\text{R}^2\text{CR}^3\text{R}^4\text{X}$, where X is a good leaving group, decompose via

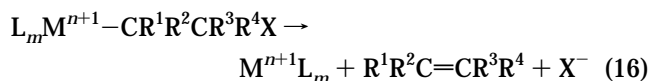

The volumes of activation of such reactions for a variety of complexes of the type $[(H_2O)_5\text{Cr}^{\text{III}}-\text{CHR}^1\text{CH}_2\text{OR}^2]^{2+}$, where $\text{R}^1 = \text{H}$ or alkyl, were measured.²⁹ It is known that all these reactions have an acid-catalyzed and an acid-independent pathway and that the first product formed is a π -complex between the produced alkene and the central metal cation. The results indicate that $-7.0 < \Delta V^\ddagger < -4.0 \text{ cm}^3 \text{mol}^{-1}$ for all these reactions and that these values are independent of the pH; i.e., the volumes of activation for the acid-independent and the acid-catalyzed pathways are identical.²⁹ These results suggest that the mechanism of these reactions can be formulated as in Scheme 6. It is proposed that the protonation equilibrium does not involve a large volume change since it does not involve a change in the net charge. For both pathways it is proposed that the formation of the transition state involves a coherent partial ring-closure process, which is associated with a volume collapse, and a stretching of the $\text{C}-\text{O}$ bond, which is associated with a volume increase.²⁹ The results clearly demonstrate that the former process has the dominant effect.

The volumes of activation for the β -elimination of ammonia from $[(H_2O)_5\text{Cr}^{\text{III}}-\text{CH}_2\text{C}(\text{CH}_3)_2\text{NH}_3^+]^{3+}$ and from $[(H_2O)_m\text{Cu}^{\text{II}}-\text{CH}_2\text{C}(\text{CH}_3)_2\text{NH}_3^+]^{2+}$ were also measured and found to be +3.1 and +3.6 $\text{cm}^3 \text{mol}^{-1}$ respectively.²⁹ The ca. 10 $\text{cm}^3 \text{mol}^{-1}$ difference between the volumes of activation for the β -elimination of OR^- and NH_3 is attributed to the fact that the $\text{C}-\text{N}$ bond is stronger than the $\text{C}-\text{O}$ bond, which makes the β -elimination of am-

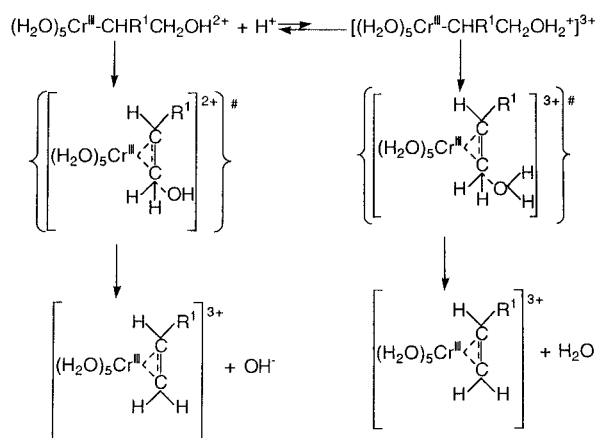
Scheme 6. Proposed Mechanism for β -Elimination Reactions from Complexes of the Type $[(\text{H}_2\text{O})_5\text{Cr}^{\text{III}}-\text{CHR}^1\text{CH}_2\text{OR}^2]^{2+}$ 

monia considerably slower than that of OR^- .³⁰ Therefore, the transition state in the elimination of OR^- is probably an early one, i.e., at the stage of ring closure, and in the ammonia system a late one, i.e., at the stage of the cleavage of the C–N bond.

Intramolecular Electron-Transfer Processes

Due to the importance of understanding the factors affecting the rate of intramolecular electron-transfer processes in inorganic and bioinorganic systems, the volume of activation for a number of such reactions was studied.

(a) The volume of activation for the reaction

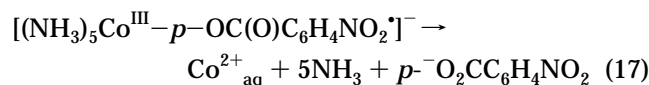

was measured.³¹ This reaction was chosen as a model system as it is a simple one and, although the electron is transferred only over a short distance, it is a relatively slow process, $k = 2.6 \times 10^3 \text{ s}^{-1}$ at 25°C .³¹ The result, $\Delta V^\ddagger = +7.5 \text{ cm}^3 \text{ mol}^{-1}$, suggests an early transition state with an intrinsic volume increase due to partial reduction of the $\text{Co}(\text{III})$ central cation and desolvation of the anion radical ligand.³¹

(b) Of special interest are the intramolecular electron-transfer reactions in metal complex-modified proteins. A challenging question in such studies is whether “long-distance” electron-transfer reactions exhibit characteristic pressure dependencies that could reveal further information on the electron-transfer mechanism itself.³² Pulse radiolysis techniques were used to measure the volumes of activation for the intramolecular electron transfer in $(\text{NH}_3)_5\text{Ru}^{\text{II}}-\text{His33}$ horse heart ferricytochrome *c* and in $(\text{NH}_3)_5\text{Ru}^{\text{II}}-\text{His39}$ *Candida krusei* ferricytochrome *c*. For both systems, $\Delta V^\ddagger \approx -18 \text{ cm}^3 \text{ mol}^{-1}$ was observed.³² For comparison purposes, the volume of activation of the intermolecular reduction of horse heart ferricytochrome *c* by $[\text{Ru}(\text{NH}_3)_6]^{2+}$ was measured, $\Delta V^\ddagger = -15.6 \text{ cm}^3 \text{ mol}^{-1}$. These results were interpreted as pointing out that the

Scheme 7. Volume Profiles for Reaction 18, L = 4-Ethylpyridine

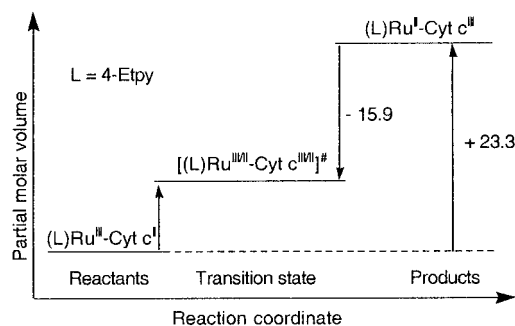

major volume change on going from the reactants to the transition state is due to the increased electrostriction at the ruthenium center. Data in the literature suggest that the oxidation of $[\text{Ru}(\text{NH}_3)_6]^{2+}$ to $[\text{Ru}(\text{NH}_3)_6]^{3+}$ is accompanied by a volume decrease of ca. $30 \text{ cm}^3 \text{ mol}^{-1}$,³³ thus, the activation volumes quoted above could principally be a consequence of the volume changes associated with the oxidation of the redox partner. This conclusion suggests that the enzyme does not change its volume during the redox process and thus probably requires only minor rearrangement prior to the electron-transfer step. This was confirmed later through application of high-pressure electrochemical measurements on cytochrome *c* and ruthenated cytochrome *c*.³⁴ More recently,³⁵ pulse radiolysis techniques were used to study the effect of pressure on a series of intramolecular electron-transfer reactions of the type

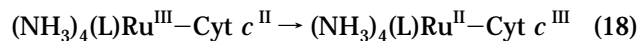

which resulted in the construction of the first complete volume profiles for such intramolecular electron-transfer processes. The volume profiles demonstrated a significant volume increase associated with the reduction of the ruthenium center. In contrast to earlier results on a series of intermolecular reactions involving cytochrome *c* and the corresponding series of pentaamine complexes, for which the volume profiles were reported to be completely symmetrical,³⁶ the studied intramolecular reactions exhibit asymmetric volume profiles (a typical example is shown in Scheme 7). The overall volume change can be accounted for in terms of electrostriction effects centered around the amine ligands on the ruthenium center.

Properties of Complexes with Uncommon Oxidation States

The pulse radiolysis technique enables the study of the properties of various complexes with uncommon, and usually unstable, oxidation states. The volumes of activation for the reactions of several such complexes were studied.

(a) **Cu(III) Complexes.** The volume of activation for the ligand exchange reaction

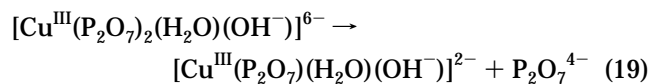

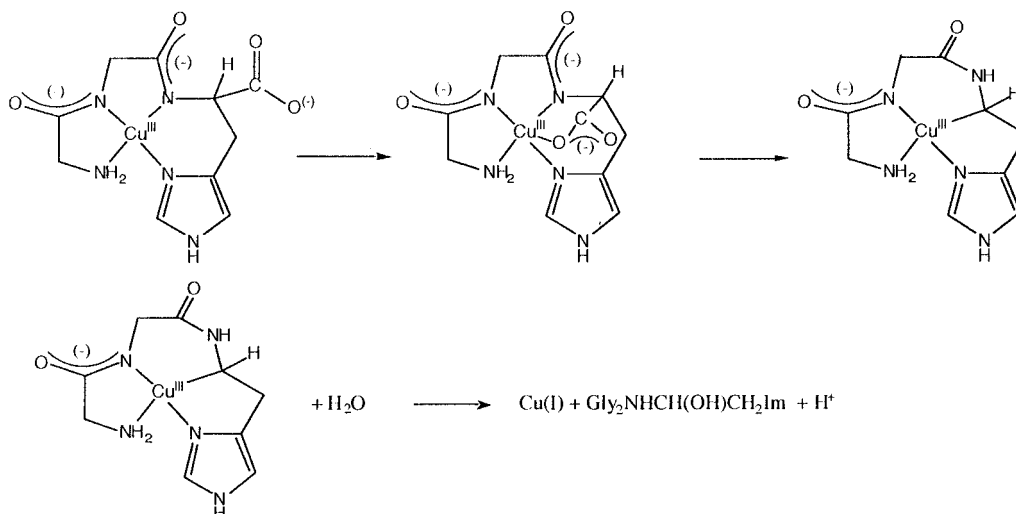
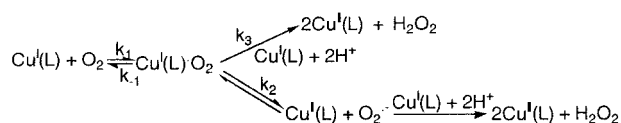
Scheme 8. Mechanism of Decomposition of the Cu^{III}(GlyGlyHis) ComplexScheme 9. Mechanism of Reaction of Cu^I(L) with Dioxygen

was determined, $\Delta V^\ddagger = -2.4 \text{ cm}^3 \text{ mol}^{-1}$.¹⁹ It should be noted that Cu(III) has a d^8 electronic configuration, and its complexes are therefore expected to be planar. Thus, the coordination geometry might differ from that proposed. The slight negative volume of activation probably indicates that the ligand exchange process occurs either via an associative mechanism, as expected, with some compensation due to charge dilution, or via an I_a mechanism.¹⁹

The mechanism of decomposition of the Cu^{III}(GlyGlyHis) complex was proposed to proceed via the mechanism outlined in Scheme 8.⁶ However, only two consecutive reactions were observed experimentally, and the question was, which ones are they? The first of these reactions has $\Delta V^\ddagger = +14 \text{ cm}^3 \text{ mol}^{-1}$,⁶ which is difficult to reconcile with a closure of the free carboxylate to form a chelate ring. This value is, however, in good agreement with expectations for a decarboxylation process. It was therefore concluded that decarboxylation is the rate-determining step observed experimentally.⁶ The ΔV^\ddagger of the second experimentally observed reaction is $+8 \text{ cm}^3 \text{ mol}^{-1}$, in agreement with expectations for the heterolytic cleavage of the Cu^{III}-C bond, as proposed.⁶

(b) Cu(I) Complexes. The kinetics of reaction of Cu^I(L), where L = (H₂O)_{*n*}³⁷ or (phen)₂,⁹ with dioxygen were studied. The measured reaction volume for equilibrium 1 in Scheme 9, $\Delta V^\circ(1) = -22 \text{ cm}^3 \text{ mol}^{-1}$ in the phenanthroline system,⁹ clearly demonstrates that the reaction has to proceed via the formation of an intermediate in which a bond is formed, since an outer-sphere redox process, in which the charge of the complex is increased from 1+ to 2+ and a monovalent anion is formed, is expected to have a considerably smaller negative volume of activation. The results suggest that $\Delta V^\ddagger(2) \approx 0 \text{ cm}^3 \text{ mol}^{-1}$ in the phenanthroline system and that k_3 approaches the diffusion-controlled limit.⁹ Surprisingly, though K_1 and

k_3 have the same values for L = (H₂O)_{*n*} and (phen)₂, $\Delta V^\circ(1) = -8.9 \text{ cm}^3 \text{ mol}^{-1}$ is observed for L = (H₂O)_{*n*}.³⁸ Several plausible sources for the difference in $\Delta V^\circ(1)$ for the two systems were discussed.³⁸

Concluding Remarks

It was the aim of this Account to point out the advantage of combining pulse radiolysis with high-pressure techniques for the elucidation of the detailed mechanisms of a large variety of inorganic reactions. Volumes of activation, along with the construction of volume profiles as outlined in this presentation, can discriminate between various mechanistic possibilities and support the assignment of a specific mechanism. In general, activation volumes can be determined more accurately than activation entropies due to the inherent extrapolation involved in the determination of the latter parameter. A correlation between these parameters should, in principle, exist since they both reveal information on order in the transition state. However, such correlations usually exist only in cases where the activation entropy has a large absolute value. In the case of smaller absolute values, the uncertainty in the activation entropy is too large for this parameter to be considered as a reliable mechanistic indicator. Therefore, the more accurately determinable activation volume is, indeed, a powerful mechanistic discrimination parameter. It is hoped that this review will also convince other research groups to apply this technique to other mechanistic studies.

The authors are indebted to their co-workers whose studies are cited in this review, since it is their work that has enabled the rather unique combination of high-pressure and pulse radiolysis kinetic techniques. They gratefully acknowledge financial support from the Deutsche Forschungsgemeinschaft, Volkswagen Foundation (R.v.E.), The German-Israeli Foundation for Scientific Research and Development (R.v.E., D.M.), the Budgeting and Planning Committee of the Council of Higher Education, the Israel Atomic Energy Commission, and the Alexander von Humboldt Foundation (D.M.). R.v.E. appreciates the stimulating collaboration with Jim Wishart (Brookhaven National Laboratory) on the development and application of high-pressure pulse radiolysis.

References

- (1) Tabata, Y. *Pulse Radiolysis*; CRC Press: Boca Raton, FL, 1990.
- (2) Meyerstein, D.; Mulac, W. A. Reduction of Co(III) Complexes by Monovalent Zinc, Cadmium and Nickel Ions in Aqueous Solutions. *J. Phys. Chem.* **1969**, *73*, 1091.
- (3) Zilbermann, I.; Winnik, M.; Sagiv, D.; Rotman, A.; Cohen, H.; Meyerstein, D. Properties of Monovalent Nickel Complexes with Tetraazamacrocyclic Ligands in Aqueous Solutions. *Inorg. Chim. Acta* **1995**, *240*, 503.
- (4) Behar, D.; Dhanasekaran, T.; Neta, P.; Hosten, C. M.; Hambright, P.; Fujita, E. Cobalt Porphyrin Catalyzed Reduction of CO₂. Radiation Chemical, Photochemical, and Electrochemical Studies. *J. Phys. Chem. A* **1998**, *102*, 2870.
- (5) Zilbermann, I.; Golub, G.; Cohen, H.; Meyerstein, D. Kinetic Stabilization of Trivalent Nickel Complexes with Tertiary-Tetra-Aza-Macrocyclic Ligands in Aqueous Solutions. *J. Chem. Soc., Dalton Trans.* **1997**, 141.
- (6) Goldstein, S.; Czapski, G.; Cohen, H.; Meyerstein, D.; van Eldik, R. The mechanism of decomposition of Cu(III)-GlyGlyHis. A pulse radiolysis study. *Inorg. Chem.* **1994**, *33*, 3255.
- (7) Bielski, I. H.; Sharma, V. K.; Czapski, G. Reactivity of Ferrate(V) with Carboxylic Acids: A Pre-Mix Pulse Radiolysis Study. *Radiat. Phys. Chem.* **1994**, *44*, 479.
- (8) Zilbermann, I.; Maimon, E.; Cohen, H.; van Eldik, R.; Meyerstein, D. Cooperative Oxidation of EDTA by Ni(III) and Dioxigen. A Pulse Radiolysis Study. *Inorg. Chem. Commun.* **1998**, *1*, 46.
- (9) Goldstein, S.; Czapski, G.; van Eldik, R.; Cohen, H.; Meyerstein, D. Determination of the Volume of Activation of the Key Reaction Steps in the Oxidation of Phenanthroline-Cu(I) by Molecular Oxygen. *J. Phys. Chem.* **1990**, *95*, 1282.
- (10) Ilan, Y. A.; Czapski, G.; Ardon, M. The Formation of CrO₂²⁺ in the Reaction of Cr²⁺ + O₂ in Aqueous Acid Solutions. *Isr. J. Chem.* **1975**, *13*, 15.
- (11) Jubran, N.; Ginzburg, G.; Cohen, H.; Koresh, Y.; Meyerstein, D. Stabilization of the Monovalent Nickel Complex with 1,4,8,11-Tetraaza-Cyclotetradecane in Aqueous Solutions by N- and C-Methylation. An Electrochemical and Pulse Radiolysis Study. *Inorg. Chem.* **1985**, *24*, 251.
- (12) Meyerstein, D. On the Kinetics of Complexation of Cuprous with Maleate and Fumarate in Aqueous Solutions, A Pulse Radiolytic Study. *Inorg. Chem.* **1975**, *14*, 1976.
- (13) Meisel, D.; Schmidt, K. H.; Meyerstein, D. Kinetics of Aquation of the Tris-Acetylacetonate Complexes of Divalent Chromium, Cobalt and Ruthenium. *Inorg. Chem.* **1979**, *18*, 971.
- (14) Navon, N.; Cohen, H.; Meyerstein, D. The Effect of Stabilising Ligands on the Rate of Reaction of Cu(I)L with CCl₃CO₂⁻ in Aqueous Solutions. I. L = HOOCCH=CHCOO⁻. *Inorg. Chem.* **1997**, *36*, 3781.
- (15) Goldstein, S.; Meyerstein, D.; van Eldik, R.; Czapski, G. Spontaneous Reactions and Reduction by Iodide of Peroxonitrite and Peroxonitrate: Mechanistic Insight from Activation Parameters. *J. Phys. Chem. A* **1997**, *101*, 7114.
- (16) Drljaca, A. A.; Hubbard, C. D.; van Eldik, R.; Asano, T.; Basilevsky, M. V.; le Noble, W. J. Activation and Reaction Volumes in Solution. *Chem. Rev.* **1998**, *98*, 2167.
- (17) Wishart, J. F.; van Eldik, R. High-Pressure Pulse Radiolysis. Modification of an Optical Cell for 2-MeV Electron Pulse Radiolysis at Pressure up to 200 MPa. *Rev. Sci. Instrum.* **1992**, *63*, 3224.
- (18) Cohen, H.; van Eldik, R.; Masarwa, M.; Meyerstein, D. Mechanism of Oxidation of Aquated Copper(II) Ions by Hydroxyl Free Radicals. A High-Pressure Pulse-Radiolysis Study. *Inorg. Chim. Acta* **1990**, *177*, 31.
- (19) Cabelli, D. E.; Wishart, J. F.; Holcman, J.; Meier, M.; van Eldik, R. Copper(III) Pyrophosphate Complexes in Aqueous Solution. A Pulse Radiolysis Study at Ambient and High Pressure. *J. Phys. Chem.* **1997**, *101*, 5131.
- (20) van Eldik, R.; Cohen, H.; Meyerstein, D. Ligand Interchange Controls Many Oxidations of Divalent First Row Transition Metal Ions by Free Radicals. *Inorg. Chem.* **1994**, *33*, 1566.
- (21) Meshulam, A.; Cohen, H.; van Eldik, R.; Meyerstein, D. Mechanism of Oxidation of 5,7,7,12,14,14-Hexamethyl-1,4,8,11-Tetraazacyclotetradecane Nickel(II) by HO₂[•] Free Radicals in Aqueous Solutions. A Pulse Radiolysis Study. *Inorg. Chem.* **1992**, *31*, 2151.
- (22) van Eldik, R.; Cohen, H.; Meshulam, A.; Meyerstein, D. The Methyl (cyclam) nickel (III) Dication in Aqueous Solutions: Determination of the Volume of Reaction and Volume of Activation for the Homolysis of the Nickel-Carbon Bond. A Pulse Radiolysis Study. *Inorg. Chem.* **1990**, *29*, 4156.
- (23) van Eldik, R.; Gaede, W.; Cohen, H.; Meyerstein, D. High-Pressure Kinetic Evidence for a Dissociative Interchange (I_d) Substitution Mechanism for Aquated Chromium(II). *Inorg. Chem.* **1992**, *31*, 3695.
- (24) van Eldik, R.; Gaede, W.; Cohen, H.; Meyerstein, D. Pressure-Assisted Formation of a Cobalt-Carbon σ Bond: A High-Pressure Pulse Radiolysis Study. *Angew. Chem.* **1991**, *30*, 1158.
- (25) Sisley, M. J.; Rindermann, W.; van Eldik, R.; Swaddle, T. W. Pressure and Temperature Effects on the Rates of Concurrent Homolytic and Heterolytic Decomposition Pathways of Aqueous 2-propyl- and 2-hydroxy-2-propylchromium(III) ions. *J. Am. Chem. Soc.* **1984**, *106*, 7432.
- (26) Gaede, W.; van Eldik, R.; Cohen, H.; Meyerstein, D. Influence of Acetate Ion on the Formation Reactions of Organochromium(III) Species. A Rapid-Scan and High-Pressure Pulse-radiolysis Study. *J. Chem. Soc., Dalton Trans.* **1993**, 2065.
- (27) De Gioia, L.; Fantucci, P. A Theoretical Study of the Methyl Ligation in Tetraaza Macrocyclic Nickel Complexes which Model the Acetyl-CoA Synthase Active Site. *Inorg. Chim. Acta* **1998**, *273*, 379.
- (28) Gaede, W.; van Eldik, R.; Cohen, H.; Meyerstein, D. Anion-Catalyzed Heterolysis of Chromium-Carbon σ Bonds. Effect of Different Anions, Temperature and Pressure. *Inorg. Chem.* **1993**, *32*, 1997.
- (29) Cohen, H.; van Eldik, R.; Gaede, W.; Gerhard, A.; Goldstein, S.; Czapski, G.; Meyerstein, D. β-Elimination and related reactions of chromium(III)-alkyl complexes in aqueous solutions. Mechanistic information from high pressure kinetic measurements. *Inorg. Chim. Acta* **1994**, *227*, 57.
- (30) Goldstein, S.; Czapski, G.; Cohen, H.; Meyerstein, D.; Shaik, S. The Effect of N-Alkylation on the Rate of β-Amino Elimination From (Cu^{II}-CRHCH₂NH₃⁺)⁺. *J. Chem. Soc., Faraday Trans.* **1993**, *89*, 4045.
- (31) van Eldik, R.; Zilbermann, I.; Cohen, H.; Meyerstein, D. Effect of Pressure on an Intramolecular Electron-Transfer Reaction Induced by Pulse-Radiolysis. *High-Pressure Res.* **1991**, *6*, 287.
- (32) Bansch, B.; Meier, M.; Martinez, P.; van Eldik, R.; Su, C.; Sun, J.; Isied, S. S.; Wishart, J. F. Mechanistic Information from the First Volume Profile Analysis for a Reversible Intermolecular Electron-Transfer Reaction Involving Penta-ammine(isonicotinamide)ruthenium and Cytochrome c. *Inorg. Chem.* **1994**, *33*, 4744.
- (33) Sachinidis, J. I.; Shalders, R. D.; Tregolan, P. A. Separation of Intrinsic and Electrostrictive Volume Effects in Redox Reaction Volumes of Metal Complexes Measured Using High-Pressure Cyclic Staircase Voltammetry. *Inorg. Chem.* **1996**, *35*, 2497.
- (34) Sun, J.; Wishart, J. F.; van Eldik, R.; Shalders, R. D.; Swaddle, T. W. Pressure Tuning Voltammetry. Reaction Volumes for Electron Transfer in Cytochrome c and Ruthenium Modified Cytochrome c. *J. Am. Chem. Soc.* **1995**, *117*, 2600.
- (35) Sun, J.; Su, C.; Meier, M.; Wishart, J. F.; van Eldik, R. Mechanistic Information from the First Volume Profile Analysis for Intramolecular Electron-Transfer Reactions. Tetraammineruthenium(ligand) Complexes of Cytochrome c. *Inorg. Chem.* **1998**, *37*, 6129.
- (36) Meier, M.; Sun, J.; Wishart, J. F.; van Eldik, R. Comparative Kinetic Analysis of Reversible Intermolecular Electron-Transfer Reactions Between a Series of Pentaammineruthenium Complexes and Cytochrome c. *Inorg. Chem.* **1996**, *35*, 1564.
- (37) Kelly, C. A.; Mulazzani, Q. G.; Blinn, E. L.; Rodgers, M. A. J. Kinetics of CO Addition to Ni(cyclam)⁺ in Aqueous solution. *Inorg. Chem.* **1996**, *35*, 5122.
- (38) Navon, N.; Cohen, H.; van Eldik, R.; Meyerstein, D. Effect of Fumarate on the Kinetics and Reaction Mechanism of Cu⁺_{aq} with Dioxygen. *J. Chem. Soc., Dalton Trans.* **1998**, 3663.

AR990067V